

***MICROMAX* 6000 TFC**

Owner's Manual

This manual is for the Installation, Operation, and Maintenance of the *MICROMAX* 6000 TFC Reverse Osmosis (RO) Drinking Water Appliance

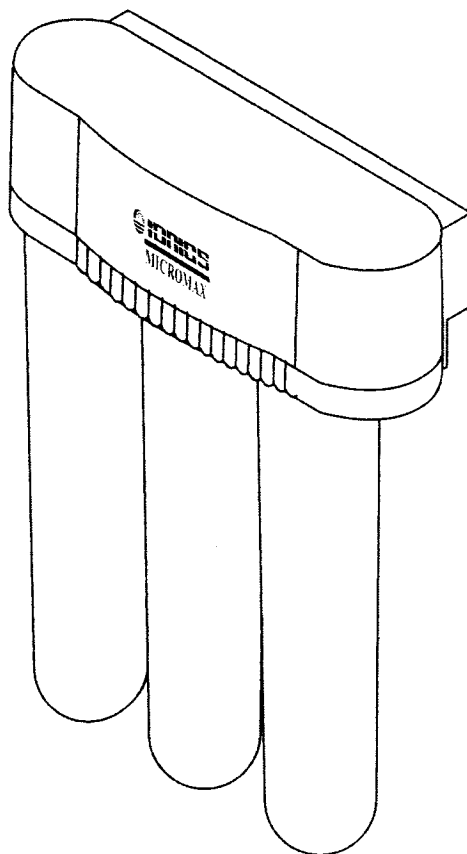

Ionics U.S. Water Group
1971 Rutan Drive
Livermore, CA 94551-7646
925-456-7000
925-456-7010 Fax
www.ionicsfidelity.com

INSTR7034 0305

INTRODUCTION

This manual explains the installation, operation and maintenance of the Ionics U.S. Water Group Reverse Osmosis (RO) Drinking Water Appliances. Please read each section of this manual carefully. The specific model chosen should be appropriate for the local water conditions and the customer's needs. Check the Performance Data Sheet for the performance characteristics and the conditions of use.

The undercounter RO drinking water appliances are designed to connect permanently to a home plumbing system. To ensure that the installation conforms to your state and local plumbing codes, it is recommended that the installation be performed by a qualified installation specialist for RO drinking water appliances or a licensed plumber. Failure to install the system as instructed will **VOID** the warranty.

**Caution: The RO membrane cartridge may be shipped with a preservative solution inside.
Make sure to flush it thoroughly as directed before the first use.**

TABLE OF CONTENTS

I. Installation Instructions

A. Determine the appliance location	3
B. Prepare the area for installation	3
C. Prepare the appliance for installation	4
D. Make the faucet mounting hole	4
E. Mount the faucet	5
F. Install the feed water valve.....	6
G. Prefill and sanitize the storage tank	6
H. Install the drain connection	6
I. Install the purification assembly and storage tank	7
J. Make the tubing connections	7
K. Install the icemaker hookup (optional).....	7
L. Start up the appliance	8
M. Flush the appliance of the preservative and check the operation	8
N. Cleanup, paperwork and customer orientation	8
O. Installation troubleshooting	9

II. Operation & Maintenance Instructions

A. Important water quality assurance requirements	10
B. Replacing the filter cartridges	10
C. Replacing the RO membrane cartridge	11
D. Sanitizing the RO appliance	11
E. Long term non-use	12

I. Installation Instructions

A. DETERMINE THE APPLIANCE LOCATION

The appliance can be located under a sink or in a basement depending on space availability and the customer's preference. If a basement installation is selected, additional tubing, hardware and fittings may be needed and a hole will have to be made from inside the cabinet, through the floor, to the basement. Never install it in an area of the home where the temperature may drop to freezing, damage to the appliance may occur.

The exact placement of the various components of the appliance will vary from installation to installation. The installer, in conjunction with the customer, must decide on where to place the faucet, tank and purification assembly by balancing the homeowner's convenience with ease of installation and servicing. (See Fig. 1).

Considerations for an icemaker or other remote hookup should be predetermined, including routing and any additional tools, fittings, and tubing that may be required.

Installation must comply with state and local plumbing codes.

B. PREPARE THE AREA FOR INSTALLATION

To save time, it is often advised to call the customer and request that they clean under the sink prior to arrival. Otherwise, remove supplies from under the sink and stack them neatly away from the working area. Arrange a light for the work area, if necessary.

Inspect the cold water supply line and determine if any special fittings, in addition to what is included in the kit, are required.

NOTE: It is a good idea at this time to check the condition of the undercounter plumbing for any existing or potential leaks. The customer should be advised of any problem so there is no misunderstanding as to who is responsible.

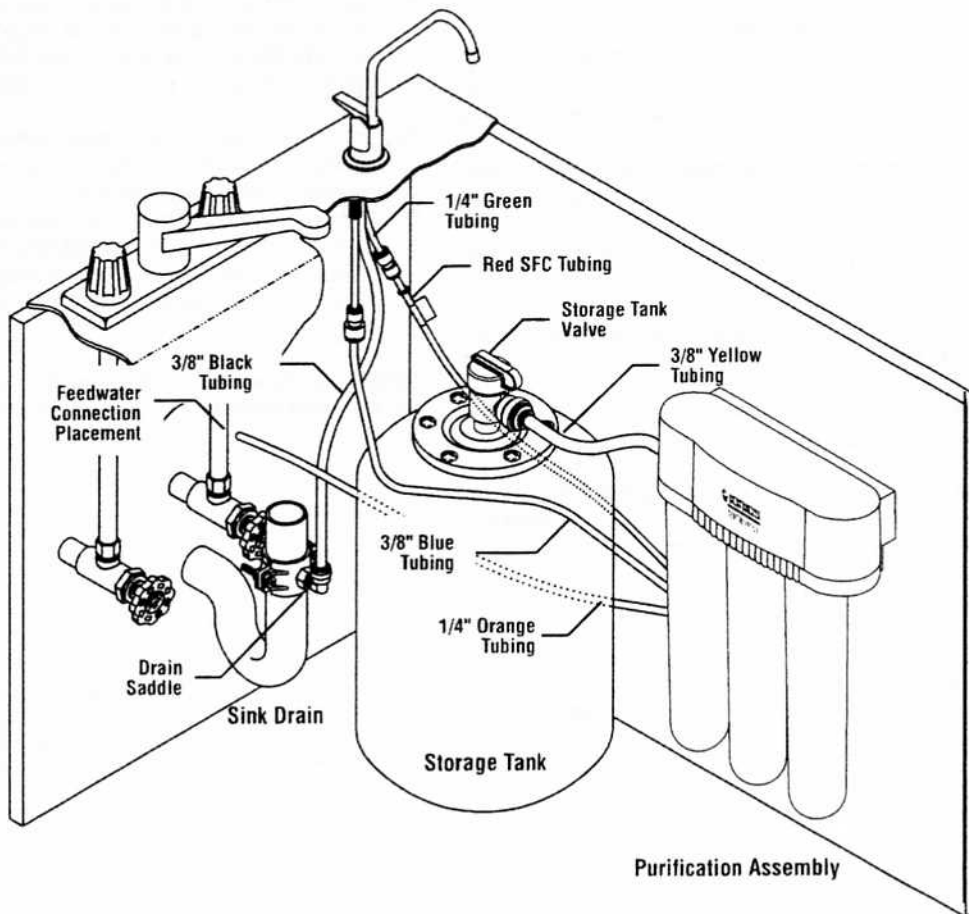

Fig. 1

C. PREPARE THE APPLIANCE FOR INSTALLATION

Open the shipping carton and remove the components. Check to see that all of the installation parts are present. They should include the purification assembly, storage tank, faucet, installation hardware, RO membrane cartridge and tubing. Check to see that the air charge in the empty tank is approximately 7 psi (48 kPa). **Note:** Check the storage tank air pre-charge with the tank valve open. Adjust it if necessary. If the optional percent rejection monitor is selected, the probes should be installed at this time. Follow the instructions that came with the monitor. To ensure you the highest level of purity, the RO membrane cartridge has been shipped separately in a sealed plastic bag. Follow the steps below to install the RO membrane cartridge.

STEP 1: Cut open the sealed plastic bag and remove the RO membrane cartridge.

STEP 2: Remove the white plug from the fitting at the bottom of the cartridge by pushing in the small white collet and pulling out the plug simultaneously. (See figure 6.)

STEP 3: Remove the red plastic cap from the top of the cartridge.

STEP 4: Connect the red SFC reject tubing by inserting it into the fitting at the bottom of the RO membrane cartridge as far as it will go. Line up the cartridge ears (see figure 9), insert the cartridge and push it into the head until it is fully seated. Twist the cartridge 1/4 turn to the right to lock it into place. The final orientation should be such that the cartridge label faces toward the front and the fitting is located towards the rear.

D. MAKE THE FAUCET MOUNTING HOLE

A wide variety of RO faucet mounting situations may be encountered. The most common are stainless steel or ceramic on metal sinks. Consult your dealer for any other materials which may be encountered.

The customer should be consulted before determining the faucet location. The faucet should be positioned so that it empties into the sink and the spout swivels freely for convenience.

If the sink already has a hole provided that can accommodate the RO faucet, then no drilling is required.

NOTE: With customer's permission, sprayers can be disconnected to provide a suitable mounting hole for the RO faucet.

IMPORTANT: It is mandatory that safety glasses be worn during the sink hole drilling operations in order to prevent eye injury.

Before drilling the hole, always check underneath the sink to ensure that nothing will interfere with mounting the faucet such as reinforcing ribs, support brackets or the cabinet construction.

Stainless steel sink, air gap faucet.

Recommended tools:

- Center punch
- Variable speed drill and high speed drill bits
- Greenlee 7/8" chassis punch (alternate 9/16" may be used for a non-air gap faucet)
- Protective gloves

Procedure:

- 1) Center punch a small indent at the center of the desired faucet location.
- 2) Slowly drill the required pilot hole for the chassis punch.
- 3) Set up the chassis punch per the instructions and tighten the nut to cut the desired hole size.
- 4) Clean up all sharp edges with a file if necessary.

Porcelain/Enamel/Ceramic sink on sheet metal or cast iron base; air gap or non air gap faucet.

Recommended tools:

- Variable speed drill
- Relton 7/8" porcelain cutter tool set
- Plumber's putty

It is important to understand what is involved in this procedure. First, the glassy layer of porcelain must be penetrated through to the base metal. Second, a center disc of porcelain must be removed while protecting the surrounding porcelain against chipping or fracturing. Third, the base metal must be drilled through to complete the hole.

Procedure:

- 1) Mark the center for the 7/8" hole.
- 2) Form a shallow putty dam around the hole area and fill it with enough water to lubricate the carbide drill bit.
- 3) Carefully drill a pilot hole through the porcelain/enamel and the base metal using a carbide type pilot drill. **Important: Always operate the drill with light pressure at a slow speed (300-400 rpm).**
- 4) Insert the pilot tip of the spring-loaded porcelain cutter into the pilot hole.
- 5) Drill the porcelain/enamel using the spring-loaded porcelain cutter, making certain a complete ring has been cut through the porcelain/enamel to the metal base.
- 6) Change to the metal cutter. With a slow speed and light pressure, cut away the inner porcelain/enamel disc down to the base metal. Make certain that the cutter does not touch the outer rim of the cut porcelain/enamel. Continue with this bit to cut completely through the metal.

IMPORTANT: When using a porcelain cutter it is critical that it is always in a sharpened condition. Dull cutters have been known to chip sinks.

E. MOUNT THE FAUCET

Undercounter installations generally require that the faucet's built-in air gap be used. In basement installations, the built-in air gap does not have to be used if one is provided elsewhere on the drain line.

Undercounter Installation With An Air Gap Faucet:

- 1) Familiarize yourself with all of the components shown in the air gap faucet diagram. (See Fig. 2)
- 2) Remove the hardware from the threaded nipple of the faucet, except for the chrome base plate and the rubber washer. The rubber washer may be replaced with a bead of plumber's putty for a neater appearance.
- 3) Connect the 1/4" green tubing supplied in the installation kit to the smaller barb on the air gap faucet. Push it on firmly until it seats.
- 4) Connect the supplied 3/8" black tubing to the larger barb on the air gap faucet. Push it on firmly until it seats.
- 5) From above the sink counter-top, feed the air gap tubing and the

threaded nipple through the faucet mounting hole and position the faucet spout over the sink.

- 6) From below the sink/countertop, install the white spacer (open side toward the air gap tubing), flat washer and hex nut onto the threaded nipple and tighten it by hand.
- 7) Back off on the hex nut just enough to slide the slotted washer (open side toward the air gap tubes) between the white spacer and the underside of the sink/countertop.
- 8) After rechecking the faucet orientation, tighten the hex nut with a 9/16" wrench until the faucet feels secure.
- 9) From above the sink, make any minor orientation corrections by turning the faucet on its flats with a padded adjustable wrench. Use care not to mar the finish.

Faucet with Air Gap

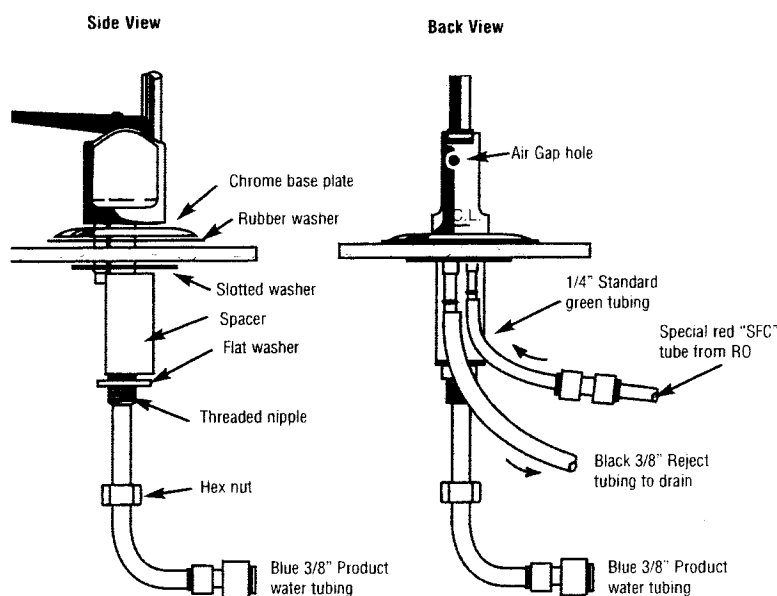

Fig. 2

F. INSTALL THE FEED WATER TAPPING VALVE AND TUBING

- 1) Consult the manufacturer's installation instructions.
- 2) Connect one end of the orange tubing to the feedwater valve.

G. PREFILL AND SANITIZE THE STORAGE TANK

Prefilling the storage tank is always recommended so that there is pressure to check for leaks as well as sufficient water to flush the carbon postfilter. The RO Drinking Water Appliance is furnished with a container of special sanitizing granules. It is important to use a sanitizer when prefilling the tank so the solution can sanitize the tubing, fittings, and the faucet at start up.

- 1) Thread the taped 3/8" x 1/4" tank fitting into the tank valve. Do not over tighten. Open the tank valve so that the tank valve handle is parallel to the valve body. Locate the enclosed container of sanitizing granules, open it and pour the contents into the end of the tank valve.
- 2) Disconnect the 3/8" yellow tubing from the back of the purification assembly and connect one end of it into the tube fitting located on the tank valve.
- 3) Connect the other end of the 3/8" yellow tubing to the 3/8" x 1/4" union connector included in the tank sanitization kit.
- 4) Connect the free end of the 1/4" orange feedwater tubing to the other end of the 3/8" x 1/4" union connector.
- 5) Open the feedwater valve (making sure the tank valve is still open) and allow the tank to fill (about 3 minutes).
- 6) Close the feedwater tapping valve and the tank valve fitting. Set the tank aside while proceeding with the rest of the installation (the sanitizing solution should be kept in the tank for at least 15 minutes).

NOTE: If you encounter difficulty in removing the tubing from the tank, make sure the tank valve is closed and then cut the yellow tubing approximately 1" away from the tank valve fitting to relieve the pressure. Remove the 1" piece from the tank fitting.

NOTE: If an alternate storage tank is used, it should be sanitized with unscented household bleach (5-1/4%). Use 3 ml. (1/2 teaspoon) of bleach for a 2.5 gallon tank.

- 7) Reconnect the 3/8" yellow tubing to the back of the purification assembly.

IMPORTANT: After the installation is complete, it is recommended that the 3/8" x 1/4" union connector be saved for future use in tank sanitization.

H. INSTALL THE DRAIN CONNECTION

IMPORTANT: Before starting this procedure, inspect the condition of the drain piping, especially in older homes where the traps and tailpieces can be deceptively thin and frail. If they are in poor condition, it is wise to inform the customer that the condition should be remedied.

IMPORTANT: Some local plumbing codes may prohibit the use of saddle-type valves and/or drain connections. The use of saddle-type valves are prohibited in Alaska, Delaware, Idaho, Kentucky, Massachusetts, Michigan, Minnesota, New Hampshire, North Dakota, Ohio, and South Dakota. Check your local plumbing codes for any restrictions that apply. Massachusetts CMR 248 strictly prohibits the use of saddle-type valves. The feedwater connection must conform to applicable plumbing codes.

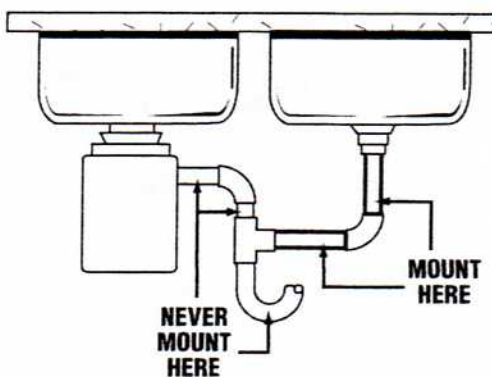

Fig. 4

Undercounter Installation:

The drain saddle is designed to fit around a standard 1-1/2" OD drain pipe. For smaller (lavatory type) or larger (ABS pipe) drains, consult your dealer for special drain saddles.

The drain saddle should always be installed above (before) the trap and on the vertical or horizontal tailpiece. Never install the drain saddle close to the outlet of a garbage disposal because plugging of the RO drain line may occur. (See Fig. 4)

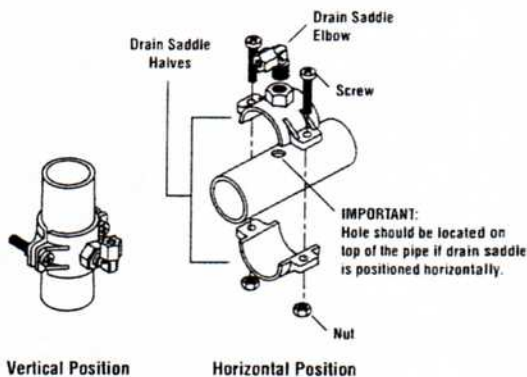

Fig. 5

- 1) Position the threaded half of the drain saddle at the selected location and mark the pipe through the threaded opening.
- 2) Drill a 1/4" hole at the marked location through one side of the drain tailpiece.
- 3) Position both halves of the drain saddle on the drain pipe so that the threaded opening is lined up with the hole in the drain pipe.
- 4) Use the screws and nuts to clamp the drain saddle onto the drain pipe. Make sure that there is equal space between saddle halves on each side. Do not overtighten. (See Fig. 5)
- 5) Orient the elbow in the direction of the RO faucet location.

