

GE Pro Elite™

DRINKING WATER SYSTEM WITH WATER QUALITY MONITOR MODEL RO-450

INSTALLATION, OPERATION & SERVICE MANUAL



Tested and certified by NSF International against NSF/ANSI Standard 58 for the reduction of the claims specified on the Performance Data Sheet.

TABLE OF CONTENTS

	Page
SECTION I. INTRODUCTION	3
SECTION II. SPECIFICATIONS	4
SECTION III. PREPARATION	5
A. Major System Components.....	5
B. Tools Recommended for Installation.....	7
C. Site Selection For Major System Components	7
SECTION IV. INSTALLATION STEPS	8
A. Faucet with Water Quality Monitor Installation.....	8
B. Feed Water Saddle Valve Installation	10
C. Drain Clamp Installation.....	10
D. R.O. Manifold Assembly Installation	11
E. Position the Drinking Water Holding Tank and Make the Final Hose Connections	11
F. Start Up.....	12
SECTION V. OPERATION AND MAINTENANCE	12
A. Normal Operation.....	12
B. Changing Modules	13
C. Changing the In-Line Activated Carbon Post Filter	13
SECTION VI. TROUBLE SHOOTING GUIDE.....	16
EXPLODED VIEW AND PARTS LIST	18

CAUTION:

The Centers for Disease Control and Prevention (CDC) and the Environmental Protection Agency (EPA) have issued guidance to people with severely weakened immune systems who may want to take extra precautions to reduce the risk of infection with Cryptosporidium from drinking water. This guidance pertains to people with HIV/AIDS, patients receiving treatment for cancer, recipients of organ or bone marrow transplants, transplant patients taking immunosuppressive drugs, and persons who have congenital immunodeficiencies.

The EPA has stated that they do not know the significance of drinking water compared to other possible sources of Cryptosporidium to determine how most people become infected. The CDC-EPA guidance suggests that immunosuppressed individuals discuss their risks with their health care provider.

This drinking water system is tested and Certified by NSF International to NSF/ANSI Standard 58 for cyst reduction. It meets the NSF/ANSI standard of reducing at least 99.95%* of cysts (including Cryptosporidium), however, because this is not 100%, immunosuppressed individuals should take the extra precaution of boiling their drinking water. According to the CDC-EPA, bringing water to a rolling boil for one minute is the most certain approach for killing Cryptosporidium.

All individuals should take adequate precautions when changing the filter cartridges, including wearing protective gloves, to avoid direct contact with the exhausted cartridges.

*For complete specifications, refer to the Performance Data Sheet.

SECTION I. INTRODUCTION

Your new Reverse Osmosis (R.O.) Drinking Water System uses a combination of filtration technologies to reduce unwanted contaminants in a water supply. The following steps combine to give you the best in clear sparkling drinking water:

MECHANICAL FILTRATION—The Sediment Module has been designed to reduce the larger particles such as silt, rust and scale. Its 5 micron (equal to 0.0002 inch) nominal rating helps to give maximum life to the R.O. Membrane.

ACTIVATED CARBON—The Activated Carbon Module contains carbon particles with a vast network of pores. The tremendous surface area of these pores (typically 800–1200 square meters per gram of carbon) gives the carbon very good adsorptive sites for substances that contribute to tastes and odors. The activated carbon in the Module is designed to reduce any chlorine that may be present in the feed water. This pretreatment is necessary for membrane protection.

REVERSE OSMOSIS MEMBRANE—The R.O. Membrane is the heart of the filtration system. It is designed to reduce the dissolved mineral content of the water. Minerals picked up in the environment by the water are measured as Total Dissolved Solids (TDS). In the Reverse Osmosis process, dissolved minerals are separated from the incoming water (Feed Water) to produce the product water (the Permeate). The excess minerals are rinsed to drain (the Reject Water).

The membrane is a specially constructed, fully aromatic polyamide film, and is classified as a Thin Film Composite (T.F.C.).

The spiral wound construction of the R.O. Membrane provides maximum surface area for water production and is less susceptible

to fouling by particulate matter, turbidity and colloidal materials.

IN-LINE ACTIVATED CARBON POST FILTER

The In-Line Activated Carbon Post Filter is located after the Holding Tank and has been designed to reduce the tastes and odors that may pass through the system. It adds a final polish to the water.

AUTOMATIC SHUTOFF VALVE—The ASO Valve senses when the Holding Tank is full and closes the feed water supply to prevent excess reject water from going to drain when the unit is not producing water.

WATER QUALITY MONITOR—The Water Quality Monitor has been integrated into the faucet base for instant monitoring at the touch of a button. The monitor compares the level of the Total Dissolved Solids in the incoming (feed) water versus the product water and calculates the percent rejection. The monitor is preset to indicate a level of 75% rejection.

A green light indicates that the percent rejection is at or above the set (desired) value and that the system is producing quality water.

An amber light indicates that the product water quality is less than acceptable. Because the Water Quality Monitor was designed to operate best while the system is making water, a false reading may occur if tested when your R.O. drinking water system is not making water. Please empty the Holding Tank, wait 15 minutes for the system to begin making water, and test your water quality again. If the Water Quality Monitor light is still amber, please contact a water treatment professional for service. The Water Quality Monitor requires a 9 volt battery, which is included.

IMPORTANT NOTICES:

This reverse osmosis system contains replaceable treatment components critical for effective performance. It is the user's responsibility to, and the manufacturer strongly recommends that the user, periodically test the product water to verify the system is performing satisfactorily. See the test kit(s) for sampling instructions.

This system is acceptable for treatment of influent concentrations of no more than 27 mg/L nitrate and 3 mg/L nitrite in combination measured as N and is certified for nitrate/nitrite reduction only for water supplies with a pressure of 280 kPa (40 psig) or greater.

This system conforms to NSF/ANSI Standard 58 for pentavalent arsenic reduction. See the Performance Data Sheet and Arsenic Facts section for an explanation of reduction performance.

DO NOT USE WITH WATER THAT IS MICROBIOLOGICALLY UNSAFE OR OF UNKNOWN QUALITY, WITHOUT ADEQUATE DISINFECTION BEFORE OR AFTER THE SYSTEM.

Systems certified for cyst reduction may be used on disinfected water that may contain filterable cysts.

SECTION II. SPECIFICATIONS

TABLE A – QUALIFIED SYSTEM PERFORMANCE

Because the performance of an R.O. Membrane is highly dependent upon pressure, temperature and TDS, the following should be used for comparison purposes only.

	U.S.	Metric
Membrane Production ¹	41-53 gpd	155–201 lpd
Membrane TDS Reduction ¹	96% minimum	96% minimum
System Production ²	14 gpd	53 lpd
Recovery Rating ²	38%	38%
Efficiency Rating ²	22%	22%
TDS Reduction ²	90%+ typical	90%+ typical
Drain (reject water) Flow	3–5 x product flow	3–5 x product flow
Empty Storage Tank Precharge	5–7 psig air	35–48 kPa air
Storage Tank Capacity ²	1.8 gallons	6.8 liters

¹ Industry standards measure R.O. Membranes performance with no backpressure on the product water, at 65 psig (448kPa) and 77°F (25°C). Further conditions on the above are 250 ppm TDS. Production rate and TDS reduction figures are for a new Membrane that has been rinsed for 24 hours. The production rate of a new Membrane can decrease by 10% per year or more, depending upon the scaling and fouling tendencies of the Feed Water.

² Measured at 50 psig, 77°±2° F, 750±40 mg/l TDS per section 6 of NSF/ANSI Standard 58. Recovery rating means the percentage of the influent water to the membrane portion of the system that is available to the user as reverse osmosis treated water when the system is operated without a storage tank or when the storage tank is bypassed. Efficiency rating means the percentage of the influent water to the system that is available to the user as reverse osmosis treated water under operating conditions that approximate typical daily usage. This reverse osmosis system contains a replaceable component critical to the efficiency of the system. Replacement of the reverse osmosis component should be with one of identical specifications, as defined by the manufacturer, to assure the same efficiency and contaminant reduction performance.

TABLE B – RECOMMENDED OPERATING LIMITS FOR FEED WATER

Specifications	T.F.C. Membrane
Water Pressure	40–100 psig (280–690 kPa)
TDS	2000 ppm (also mg/l) max.
Temperature	40–100°F (4–38°C)
pH	4–11 (optimum rejection at pH 7.0 - 7.5)
Hardness	Less than 10 gpg (170 mg/l) or soften
Iron	Less than 0.1 ppm (also mg/l)
Manganese	Less than 0.05 ppm (also mg/l)
Hydrogen Sulfide	None
Chlorine	See note
Bacteria	Must be potable**

NOTE: Chlorine will damage a T.F.C. Membrane. The Activated Carbon Module has been designed to reduce chlorine from the incoming water. Change filter every 6 months, more often if the water contains more than 1 ppm chlorine.

****DO NOT USE WITH WATER THAT IS MICROBIOLOGICALLY UNSAFE OR OF UNKNOWN QUALITY, WITHOUT ADEQUATE DISINFECTION BEFORE OR AFTER THE SYSTEM.**

SECTION III. PREPARATION

A. Major System Components

The following components comprise the R.O. Drinking Water System. (Refer to Fig. 1, below for general system layout.)

- An R.O. Manifold assembly.
- Housing and Housing O-ring.
- A Drinking Water Holding Tank.
- A Dispensing Faucet with Water Quality Monitor Assembly.
- A Feed Water Saddle Valve.
- A Drain Clamp.
- Plastic Tubing and tube connectors.
- A Reverse Osmosis Membrane sealed in a plastic bag.
- A Sediment Module, shrink wrapped.
- An Activated Carbon Module, shrink wrapped.
- An In-Line Activated Carbon Post Filter, shrink wrapped.
- Other items necessary for installation may include wood screws or machine screws and nuts for mounting the manifold, or concrete anchors for hanging on basement wall. Additional tubing or tube connectors. Plastic wire ties for organizing tubing.

TYPICAL RO-450 UNDER SINK INSTALLATION DIAGRAM

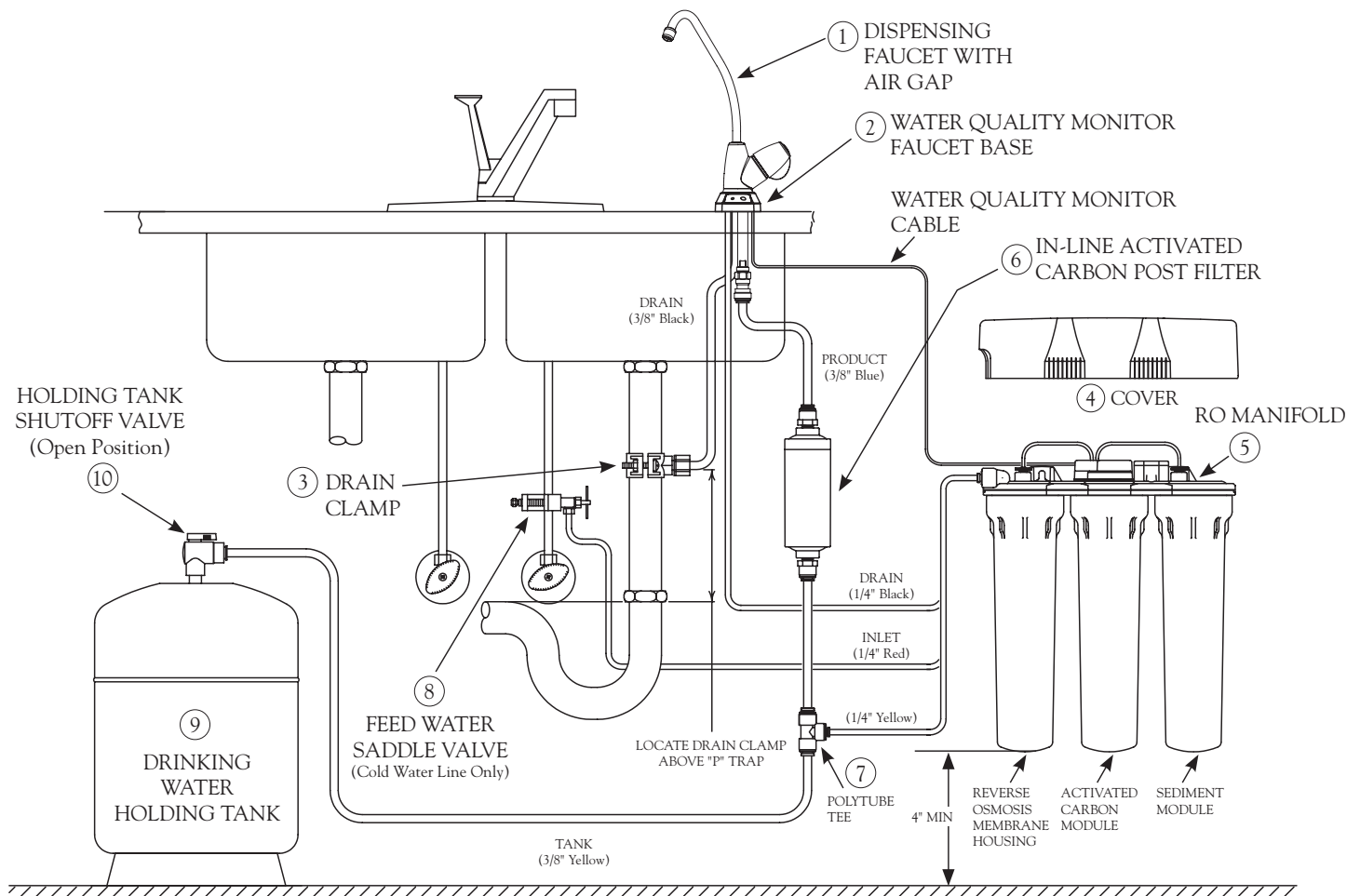
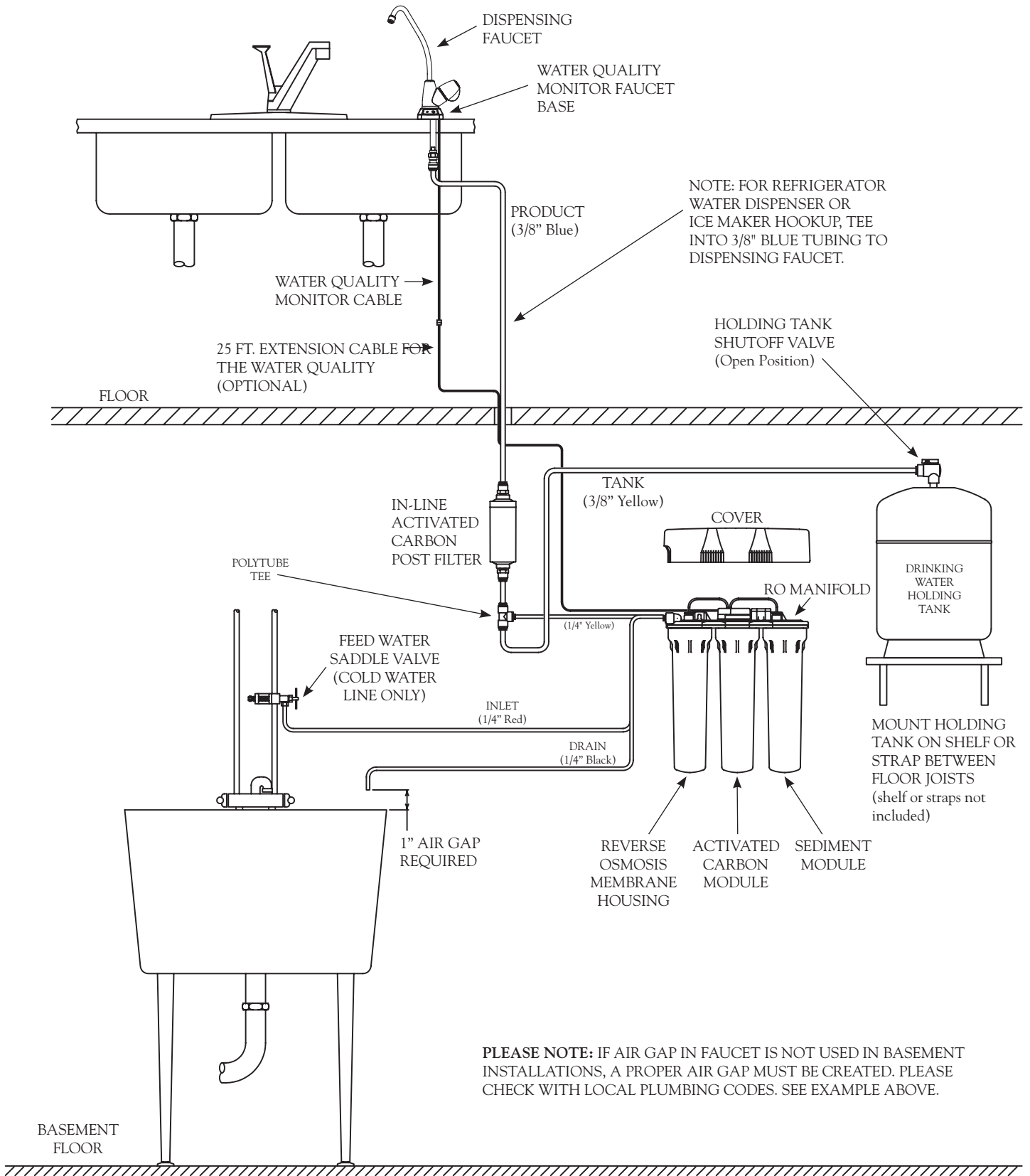

Figure 1

OPTIONAL RO-450 BASEMENT INSTALLATION DIAGRAM



B. Tools Recommended for Installation

The following tools will cover most of the installation sites encountered:

1. $\frac{3}{8}$ " variable speed electric drill.
2. Extension work light with outlet.
3. Safety glasses.
4. $\frac{1}{4}$ " porcelain hole cutter kit.
5. $\frac{1}{4}$ " Greenlee hole punch and $\frac{1}{8}$ " and $\frac{1}{2}$ " metal drill bits for pilot hole.
6. Center punch and hammer.
7. $\frac{1}{4}$ " wood bit.
8. Concrete drill bits.
9. Assorted wood and metal drill bits including $\frac{7}{32}$ " metal drill bit.
10. Phillips head and flat blade screwdrivers.
11. $\frac{1}{2}$ ", $\frac{9}{16}$ " and $\frac{5}{8}$ " open end wrenches.
12. 10" Crescent wrench with jaws taped to hold faucet.
13. Basin wrench or 10" pipe wrench.
14. Teflon tape.
15. Wide masking tape or duct tape.
16. Plastic tubing cutter.
17. Extra plastic tubing.
18. Low range air pressure gauge.
19. Bicycle hand air pump.
20. Small bottle of liquid chlorine bleach.
21. Graduated measuring cylinder.
22. Paper towels, wisk broom and assorted clean up materials.

C. Site Selection for Major System Components

The R.O. System was designed to fit under a sink, however, because of space limitations or other reasons, the system's flexible design allows for other locations. When determining the location remember that access to a cold water tap line, the household drain, and ease of filter replacement are important considerations.

All components and tubing should be located in an area not exposed to freezing temperatures. If winter temperatures are severe, the area should be above the minimum temperature listed in Table B, page 4 for proper performance. Do not expose unit or tubing to direct sunlight.

1. **Dispensing Faucet**—The faucet should be placed near the sink where drinking water is normally obtained. Convenience of use (filling of water pitchers and glasses), and an open area beneath the faucet under the sink for attaching product and drain tubing are considerations. A 2" diameter flat surface is required above and below the installation site. The thickness of the mounting surface should not exceed $\frac{1}{4}$ ". Watch for strengthening webbing on the underside of cast iron sinks.
2. **Drinking Water Holding Tank**—The Holding Tank may be placed where it is convenient within 10 feet of the faucet; under the sink or in an adjacent cabinet are best the choices. If a longer run of tubing is required, the tubing should be the $\frac{3}{8}$ " diameter OD size to prevent a high pressure drop. Remember, these tanks can weigh up to 30 pounds when full of water; a firm, level area is required.
3. **R.O. Manifold Assembly**—The manifold can be installed on either the right or left side of the under-sink area or a cabinet. The right side is recommended because all the tubing will be to the back of the cabinet and out of the way. Installation in the basement is also an option; one location is near the laundry/utility sink where cold potable water and drain access are handy. The mounting location should allow adequate clearance and accessibility for cartridge changes.
4. **Feed Water Connection**—The Feed Water Saddle Valve should be located as close to the manifold assembly as possible. USE A POTABLE COLD WATER SUPPLY ONLY. Softened water is preferred as it will extend the life of the R.O. Membrane.
5. **Drain Connection**—The waste water must go to drain through an anti-siphon air gap. The air gap is provided for in the base of the faucet. If discharging into a utility sink or standpipe, an air gap of greater than 1" above the flood rim must be provided.

Do NOT connect the system drain line to the dishwasher drain or near the garbage disposal. Backpressure from these units may cause the air gap to overflow.

SECTION IV. INSTALLATION STEPS

All plumbing should be done in accordance with state and local plumbing codes.

NOTE: Some codes may require installation by a licensed plumber; check with the local plumbing authority prior to installation.

In restricted under-sink areas, it may be easier to install the faucet first. Allow adequate tubing lengths for any final component position.

A. Faucet With Water Quality Monitor Installation

The faucet contains an anti-siphon air gap. While the system is producing water, the drain water flows from the R.O., through the air gap and then to the household drain. The purpose of the air gap is to prevent water in the drain from backing up into the R.O. Drinking Water System.

The easiest installation is to use an existing spray attachment hole. If the spray faucet hole is not available, then the sink top must be drilled.

1. Mark the location of the center of the faucet base.
- 2a. Drilling a stainless steel sink:
 - Center punch the hole to provide a starting point for the drill.
 - Start with a smaller drill as a pilot, and then drill a 1/2" diameter hole to accept the bolt of a 1 1/4" Greenlee Hole Punch (1 1/4" chassis punch).
 - Clean away any chips.
 - Install the punch and tighten the nut to cut the hole.
 - Deburr any sharp edges.

2b. Drilling a porcelain sink:

It is best to use a special 1 1/4" diameter cutter designed for porcelain. A carbide tipped masonry bit is a second choice.

- Place a piece of tape over the area to be drilled to help prevent chipping.
- Drill a pilot hole for the porcelain cutter. Use the pilot drill supplied with the kit or a carbide tipped drill.
- When drilling the 1 1/4" hole, drill slowly and carefully; the porcelain chips easily.
- After drilling, clean the area well. Iron filings, if left in place, can cause rust stains.

2c. Drilling a counter top:

NOTE: The counter top must be less than 1 1/4" thick. Treat ceramic tile as porcelain until the tile is penetrated, then use the carbide tipped metal cutter.

Formica counter tops may be drilled with a good 1 1/4" wood bit; drilling a 3/32" pilot hole will help keep the bit going straight.

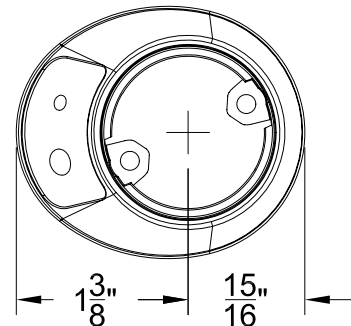

3. The hole in the Monitor Housing should be centered on the mounting hole. If cutting or drilling a mounting hole, please note that the Monitor Housing is elliptical and the hole which runs through it is off center from front to back.

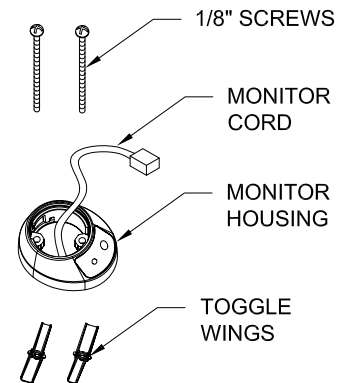

4. Feed the Monitor Cord through the 1 1/4" diameter Monitor Housing opening so that it is positioned above the Monitor Housing.

Assemble the 1/8" Screws & Toggle Wings into the Monitor Housing. Adjust the Wings approximately 1" plus the thickness of the mounting surface away from the bottom of the Monitor Housing.

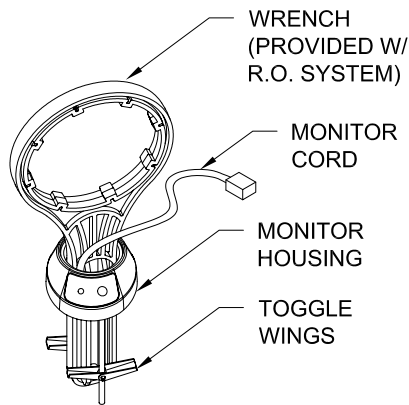

5. Place the Toggles of the Monitor Housing Assembly through the mounting hole on the sink or counter top.

Drop the handle of the Wrench through the Monitor Housing opening. This will separate and orient the Toggle Wings. Position the Monitor Housing so that the display is facing forward.

Tighten the 1/8" Screws with a Phillips tip screwdriver. When the Toggle Wings make contact with the mounting surface, adjust the Monitor Housing to the exact desired position. Tighten the 1/8" Screws an additional 2 –3 turns while holding the Monitor Housing in place.

Drop the Monitor Cord back through the Monitor Housings opening.

HANDLE
RIGHT

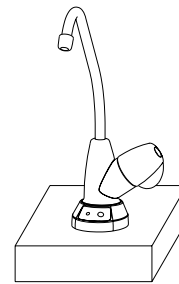

HANDLE
LEFT

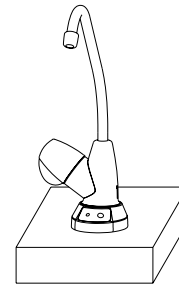

7. Determine which direction the handle should face (right or left). With the handle facing the chosen direction, slide the fastened Polytubes through the Monitor Housings 1 1/4" diameter opening and slide the Faucet Assembly into the Monitor Housing, lining up the tabs of the Faucet with the slots on the Housing. The Faucet Assembly may have to rotate slightly to get the tabs into the slots. When aligned, apply firm downward force to get the Faucet to fully seat. After the Faucet Assembly is seated, lock it into place by rotating it clockwise about 30 degrees.

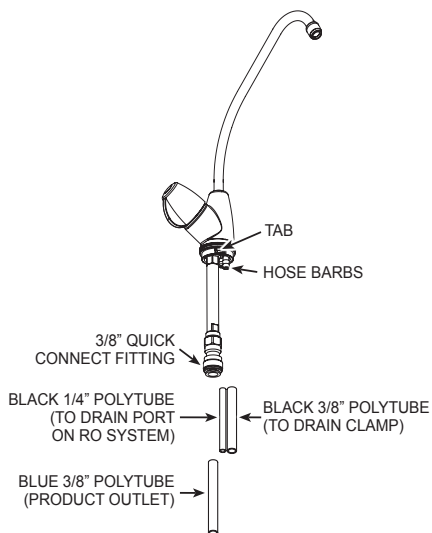

6. Connect the tubing to the Faucet. Push the Blue 3/8" Polytube into the 3/8" Quick Connect Fitting. Push the Black 3/8" Polytube onto the large Hose Barb. Push the Black 1/4" Polytube onto the small Hose Barb.

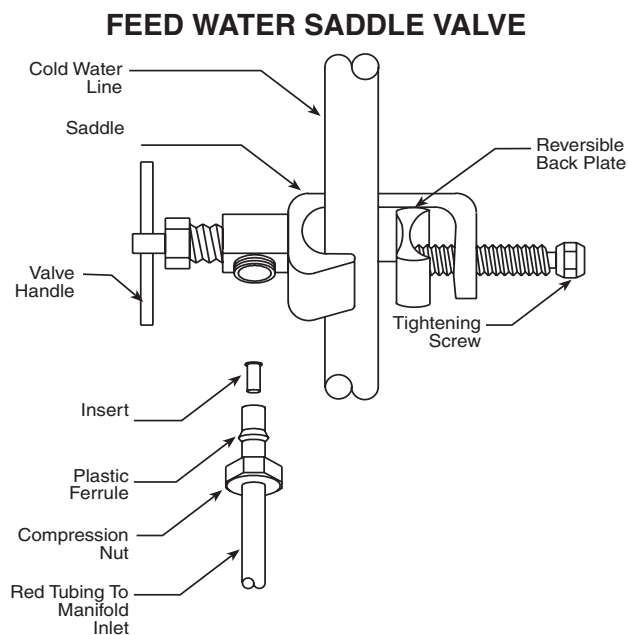

Figure 3

B. Feed Water Saddle Valve Installation

Decide on location. Do NOT connect to a hot water feed line. If you are not sure of the supply, run the hot water and feel the supply piping. Water over 100°F may cause permanent damage to the R.O. Membrane. (Refer to Fig. 3.)

1. Shut off the water supply and drain the line.

2a. To install on (soft) Copper Tubing supply line:

- Turn the Handle of the Feed Water Saddle Valve counter clockwise (outward) until the lance does not protrude from the gasket. It may have to be pushed in.
- Assemble the Feed Water Saddle Valve on the tubing.
 - for $\frac{3}{8}$ " OD tubing use the back plate side with the small groove to prevent distortion of the tubing.
 - for larger tubing (up to $\frac{5}{8}$ " OD) use the large groove of the back plate.
- Assemble and tighten the brass screw.
- To pierce the tubing, turn the Valve Handle fully clockwise (inward). A small amount of water may escape from the outlet until it is fully pierced.
- When you feel the Valve Handle firmly seated in the clockwise direction, the copper tube is pierced and the valve is closed.

2b. To install on (hard) Steel or Brass Tubing supply line.

- The supply line should now be drained. Use a battery powered or properly grounded drill to avoid shock hazard.
 - Drill a $\frac{3}{16}$ " hole in the supply line; (do not drill through the opposite wall).
 - Turn the handle to expose the lance no more than $\frac{3}{16}$ " beyond the rubber gasket.
 - Place the body of the valve over the hole so that the lance fits into the hole.
 - Assemble and tighten the brass screw.
 - Turn the Valve Handle clockwise (inward) until firmly seated. The valve is closed.
3. With the Feed Water Saddle Valve closed, open the sink faucet and the water supply and allow the water to run for a few minutes to flush any debris caused by the installation.
- Close the faucet and check the Feed Water Saddle Valve for leaks.

$\frac{3}{8}$ " DRAIN CLAMP ASSEMBLY

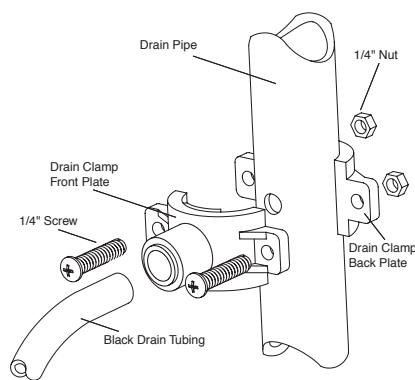

Figure 4

C. Drain Clamp Installation

The following are instructions for discharging into the sink drain pipe. (Refer to Fig. 1.)

1. Position the Drain Clamp on the sink drain pipe above the drain trap. Allow room for drilling. Tighten securely.
2. Use a battery powered or properly grounded drill. Using the Clamp port as a drill guide, drill a $\frac{7}{32}$ " hole through the wall of the drain pipe. Do NOT penetrate the opposite side of the pipe.
3. Locate the $\frac{3}{8}$ " Black Drain Tubing connected to the Dispensing Faucet. Route to the tubing to the Drain Clamp and trim to length.

NOTE: When cutting the polytubing make clean, square cuts, failing to do so could result in poor connections and possible leaks.

CAUTION: The lowest point of the line should be the point of connection to the Drain Clamp. There should be no sag in the line as this may cause excessive noise as the reject water is flowing to drain.

Insert the tubing into the Drain Clamp. Make sure the tubing is pressed in all the way.

D. R.O. Manifold Assembly Installation

Various installation sites will require different types of mounting fasteners; be sure the fastener selected will provide a firm, solid mounting. A support panel may be necessary on thin cabinet walls or to span between wall studs on particleboard or drywall.

Do not drill through exterior cabinet walls or leave sharp wood screw points exposed in readily accessible cabinet interiors.

The close proximity of a dishwasher or a trash compactor may require special fabrication of a mounting plate.

1. The mounting bracket will accept either #10 or #12 (5mm) mounting screws spaced on 6" (15 cm) centers. Allow at least 4" (10 cm) of clearance beneath the filter housings to accommodate filter changes. Mark the two locations (the bracket can be used as a template). Install the screws and tighten them until the heads are about $\frac{5}{8}$ " from the wall.
2. Locate the $\frac{1}{4}$ " Red Feed Water Tubing. Remove the red plug from the fitting labelled "In" on the manifold and insert the tubing. Reference the special supplement sheet in the carton for proper connection of all tubing and removal of plugs. Run the tubing along its course to the Feed Water Saddle Valve, trim to length. (Refer to Fig. 1.)

Refer to Fig. 3. To the end of the red polytube install the Compression Nut, the Plastic Ferrule, and the Insert. Connect to the Feed Water Saddle Valve.
3. Locate the $\frac{1}{4}$ " Black Drain Tubing connected to the Dispensing Faucet. Remove the black plug from the fitting labelled "Drain" on the manifold and insert the tubing. The end of the Black Drain Tubing that should be inserted into the "Drain" port will have a green drain restrictor in it.

4. Locate the $\frac{1}{4}$ " yellow tubing with the tee attached to one end. Remove the yellow plug from the fitting labelled "Out" on the manifold and insert the tubing.
5. Locate the $\frac{3}{8}$ " Blue Product Water Tubing attached to the Dispensing Faucet. Firmly press one end into the tee. (Refer to Fig. 1.) The fittings will grab the tubing and seal it in place. Make sure the tubing is pressed all the way in to create a pressure tight connection.
6. Hang the Manifold Assembly on the mounting screws and tighten. **DO NOT OVERTIGHTEN.**
7. Remove the wrapping from the In-Line Activated Carbon Post Filter. Slice the $\frac{3}{8}$ " Blue Polytube where it would be convenient to install and change the In-Line Filter. Make a clean straight cut to insure proper connections. The "Out" port on the In-Line Filter should be towards the faucet. Firmly press in the tubing. The fittings will grab the tubing and hold and seal it in place. Make sure the tubing is pressed all the way in to create a pressure tight connection.

E. Position the Drinking Water Holding Tank and Make the Final Hose Connections.

1. Check the tank precharge pressure. Make sure it is between 5 to 7 psig. If not, use a bicycle hand pump or other pump to bring the pressure up to the 5 to 7 psig range.
2. Pull the cap/plug off the top of the tank where the Tank Shut-Off should go. (Refer to Fig. 1.)
3. Wrap Teflon tape three times around the $\frac{1}{4}$ " male outlet thread. Wrap in the direction of the threads (clockwise when looking down on the Holding Tank). The tape will act as a thread sealant. Screw on the Holding Tank Shut-Off Valve.
4. Locate the $\frac{3}{8}$ " Yellow Tubing. Firmly press one end into the Holding Tank Shut-Off Valve and the other end into the tee. (Refer to Fig. 1.) The fittings will grab the tubing and seal it in place. Make sure the tubing is pressed all the way in to create a pressure tight connection.

F. Start Up

1. Installing the modules and membrane and sanitizing the holding tank.
 - Open the Dispensing Faucet and close the Holding Tank Shut-Off Valve (the handle should be perpendicular to the valve body).
 - Remove the plug on the underside of the manifold labelled "SEDIMENT". Unwrap the Sediment Module. Make certain the Module O-ring is pressed firmly in the groove. Engage and firmly tighten the module hand tight only.
 - Remove the plug labelled "ACTIVATED CARBON" from the underside of the manifold. Unwrap Activated Carbon Module. Make certain Module O-ring is firmly pressed in groove. Engage and firmly tighten the module hand tight only.
 - Remove the plug labelled "Membrane" from the underside of the manifold. Trim top of membrane bag, exposing the white plastic seal. While holding onto bag, insert membrane firmly into manifold. (The O-rings should be up towards the manifold.) Remove the bag from the membrane. Take the remaining housing and insert housing O-ring into its groove. Engage and firmly tighten housing hand tight only.
 - Close the Holding Tank Valve.
 - Disconnect the yellow product water tubing that runs from the Holding Tank to the Tee (see Fig. 1). Put 50 drops of bleach (this is ½ tsp. or 3 ml) into the tubing and reconnect the Tee.
2. Rinsing the system:
 - Slowly open the Feed Water Saddle Valve fully counter clockwise.
 - Open the Holding Tank Valve.
 - Check the Air Gap on the Dispensing Faucet to be sure that the drain water is flowing. The R.O. System is now making water.
 - Do not open the Faucet for at least 8 hours.
 - Do not use the first three full tanks of water.

CAUTION: The R.O. Membrane is shipped with a preservative in it. To ensure proper rinsing of the R.O. Membrane it is important to wait at least 8 hours before emptying each tank.

When the Faucet is first opened, expect air and carbon fines (very fine black powder) from the In-Line and Activated Carbon Post Filters to be rinsed out. This is normal for the first tank of water or after the Activated Carbon Post Filters are changed.

SECTION V. OPERATION & MAINTENANCE

A. Normal Operation

1. It is normal for the Total Dissolved Solids (TDS) of the water to be higher than normal during the first 5 gallons of operation; this is due to the sanitizing solution and the new Post Filters. After this water is rinsed to drain, the removal rate should stabilize at a value of greater than 75%. The Water Quality Monitor was designed to measure water quality when the R.O. system is making water. In order to assure you are getting an accurate reading, empty the holding tank, wait 15 minutes until the system begins making water, and then test the TDS with the monitor.
2. R.O. systems produce drinking water at relatively slow rates; it can take up to 5 hours or more to fill the Holding Tank. Normal operation is to let the Holding Tank fill with water and then draw water as is needed. When the pressure in the Holding Tank falls to a given pressure (as the water is being used) the Automatic Shut-Off Valve (ASO Valve) will start water production and the system will refill the Holding Tank. When the Holding Tank is full and no water is being used, the ASO Valve will automatically shut off the feed water to conserve water. The more water that is used (up to the capacity of the system) the better the R.O. system will function. Other uses for the water are flowers, pets and rinsing glassware.

With each use it is recommended that you run the faucet for at least 10 seconds prior to using water. This is especially important if the system has not been used daily. After periods of non-use, such as a week of vacation, it is better to empty the Holding Tank and allow the system to produce fresh water for use. If the system is not used for 3-4 weeks or longer, it is a good idea to resanitize the system and to change the prefilter and post filters.

B. Changing Modules

THIS R.O. SYSTEM CONTAINS MODULES WHICH MUST BE REPLACED AT REGULAR INTERVALS TO MAINTAIN PROPER PERFORMANCE. USE ONLY FACTORY APPROVED MODULES.

All individuals should take adequate precautions when changing the filters, including wearing protective gloves, to avoid direct contact with the exhausted filters.

The recommended interval for changing the modules (not the R.O. Membrane) is every six (6) months. Typical T.F.C. Membrane life expectancy is three years. Local conditions may dictate more frequent changes.

NOTE: If the R.O. Membrane is to be replaced, see Sec. IV, F.1–2, for the proper procedure.

Use a drip pan to catch any water that may spill when the Filter Modules are removed. Refer to Fig. 1 for component location.

1. Close the Feed Water Saddle Valve by turning fully clockwise and open the Dispensing Faucet. Allow the Holding Tank to empty.
2. Loosen and remove the Sediment Module and the Activated Carbon Module. Discard the modules.
3. To sanitize the system and replace the modules:
 - Unwrap the new Sediment Module.
 - Using an eyedropper put 5 ml (this is approximately 1 tsp.) of a good quality unscented 5¼% liquid household chlorine bleach down the center tube of the Module.
 - Check the Module O-ring for proper position in its groove, engage and tighten the Module hand tight only.
 - Unwrap the new Activated Carbon Module.
 - Check the Module O-ring for proper position in its groove, engage and tighten the Module hand tight only.
 - Close the Holding Tank Valve.
 - Disconnect the yellow product water tubing that runs from the Holding Tank to the Tee (see Fig. 1, page 5). Put 50 drops of bleach (this is ½ tsp. or 3 ml) into the tubing and reconnect it to the Tee.

NOTE: Now is the convenient time to change the In-Line Activated Carbon Post Filter, see Sec. V, C.1–6.

- Slowly open the Feed Water Saddle Valve. When water begins dripping out of the Dispensing Faucet, in the following order, close the Faucet and then open the Holding Tank Valve.
- Do not open the Faucet for at least 8 hours.
- Discard the first three full tanks of water produced, they will contain chlorine.

IN-LINE ACTIVATED CARBON POST FILTER ASSEMBLY

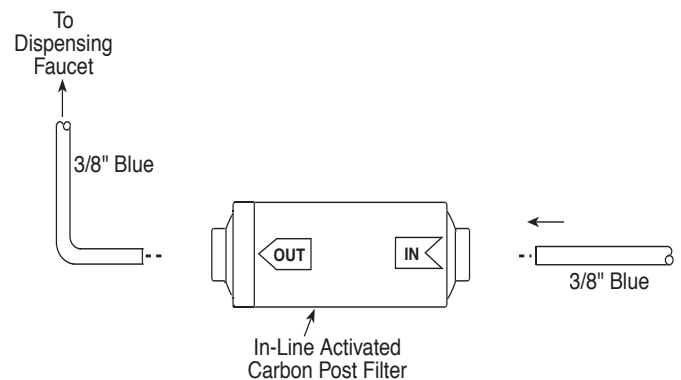

Figure 5

C. Changing the In-Line Activated Carbon Post Filter

1. Close the Feed Water Saddle Valve by turning fully clockwise.
2. Close the Holding Tank Valve and then open the Dispensing Faucet to release the pressure.
3. Remove the In-Line Activated Carbon Post Filter. Disconnect the used Post Filter by pressing in the connector's collar and at the same time pulling the tube out of the fitting.
4. Firmly reconnect the polytubes to the new Post Filter. (Refer to Fig. 5.) Make sure the tubing is pressed all the way in to create a pressure tight connection.
5. Slowly open the Feed Water Saddle Valve.
6. When water begins dripping out of the Faucet, in the following order, close the Faucet and open the Holding Tank Valve. When the Faucet is first opened, expect air and carbon fines (very fine black powder), from the new Post Filter to be rinsed out. This is normal for the first tank of water.

NOTES:

NOTES:

SECTION VI. TROUBLE SHOOTING GUIDE

Problem	Possible Cause	Solution
Low quantity of Product Water from Holding Tank	Feed Water Saddle Valve is plugged or closed.	Open Valve or unclog.
	Clogged Sediment Module or Activated Carbon Module.	Replace Modules.
	Low water pressure.	Feed Water pressure must be above 40 psig.
	R.O. Membrane is fouled.	See Feed Water operating limits. Correct cause of fouling, replace Membrane.
	Plugged In-Line Activated Carbon Post Filter.	Replace Post Filter.
	Air precharge pressure in Holding Tank is too high.	Empty water from Holding Tank, and with the faucet open, adjust air pressure to 5–7 psig (35–48 kPa) range.
	Air precharge is too low	
	Air bladder in the Holding Tank is ruptured.	Replace tank.
	Holding Tank Valve is closed.	Open Valve.
	No drain flow, the drain Drain Restrictor is plugged.	Clear or replace Drain Restrictor.
	No drain flow, the drain orifice in the Dispensing Faucet is plugged.	Clear or replace the Dispensing Faucet.
	The Check Valve is stuck.	Free check.
	The ASO Valve is malfunctioning.	Replace ASO Valve components.
Low pressure at the Dispensing Faucet	In-Line Activated Carbon Post Filter is plugged.	Replace Post Filter.
	Air precharge in the Holding Tank is too low.	Empty water from Holding Tank and with the faucet open, adjust the air pressure to 5–7 psig (35–48 kPa) range. Check for leakage at the Air Valve Stem.
	Holding Tank Valve is partially closed.	Open Valve.
	The Dispensing Faucet is out of adjustment or faulty.	Repair or replace Dispensing Faucet.
	Heavy water use, Holding Tank is depleted.	Allow Holding Tank to refill (adding a second Holding Tank will increase storage capacity).
	Low Water Production.	See Low Quantity of Product Water from Holding Tank section above.
	High Total Dissolved Solids (TDS) in the Product Water	Clogged Sediment Module or Activated Carbon Module.
Low Water Pressure.		Feed Water Pressure must be above 40 psig.
		Check Feed Water Saddle Valve.
R.O. Membrane O–ring is crimped.		Check O–ring.
R.O. Membrane brine seal is not sealing up into the manifold head.		Check the brine seal.
R.O. Membrane is expended.		If Membrane life is unusually short, find and correct the problem. Replace Membrane.

Problem	Possible Cause	Solution
High Total Dissolved Solids (TDS) in the Product Water (continued)	The Product Water and Drain Water lines are reversed.	Correct plumbing.
	No drain flow, Drain Restrictor is clogged.	Clear or replace Drain Restrictor.
	No drain flow, the drain orifice in the Dispensing Faucet is plugged.	Clear or replace Dispensing Faucet.
	The ASO Valve is not closing.	Repair or replace the ASO Valve Components
	New Activated Carbon Post Filter not rinsed completely.	Flush with several full tanks of Product Water.
	The Feed Water TDS has increased.	An increase in Feed Water TDS will give a corresponding increase in Product Water TDS.
Tastes and odors in the Product Water	The Activated Carbon Post Filter is exhausted.	Replace Filter.
	There is foreign matter in the Holding Tank.	Clean, flush and sanitize the system. Replace the filters.
	The Product Water and Drain Water lines are reversed.	Correct plumbing.
	Dissolved gasses in the Feed Water.	Pretreat Feed Water to remove dissolved gasses.
	Increase in Product Water TDS.	See high TDS in the Product Water section.
Drain Water overflows at the Dispensing Faucet	Air Gap is blocked.	Clear Air Gap. Rinse with vinegar for removal of calcium buildup.
	Drain tubing is clogged.	Clear tubing.
	Drain Clamp hole is misaligned.	Align with hole in the drain pipe.
	Excessive drain flow rate.	Replace Drain Restrictor.
	Faucet leaks or drips	Leaks from base of the delivery tube.
Amber light on Water Quality Monitor	System not being used for extended period of time	Empty storage tank. Wait 15 minutes (the system is making water) and test water quality again.
	Filters are plugged or membrane is fouled or exhausted.	Replace filters and/or membrane.
Fitting leaks in general	Close the Feed Water Saddle Valve and relieve pressure before disconnecting any tubing or replacing any fitting. Before replacing a fitting, re-cut the tubing and re-insert into the fitting to see if that solves the leak. If pipe threads are leaking, remove and retape with Teflon tape.	

EXPLODED VIEW & PARTS LIST

19.....Nitrate/Nitrite Test Kit

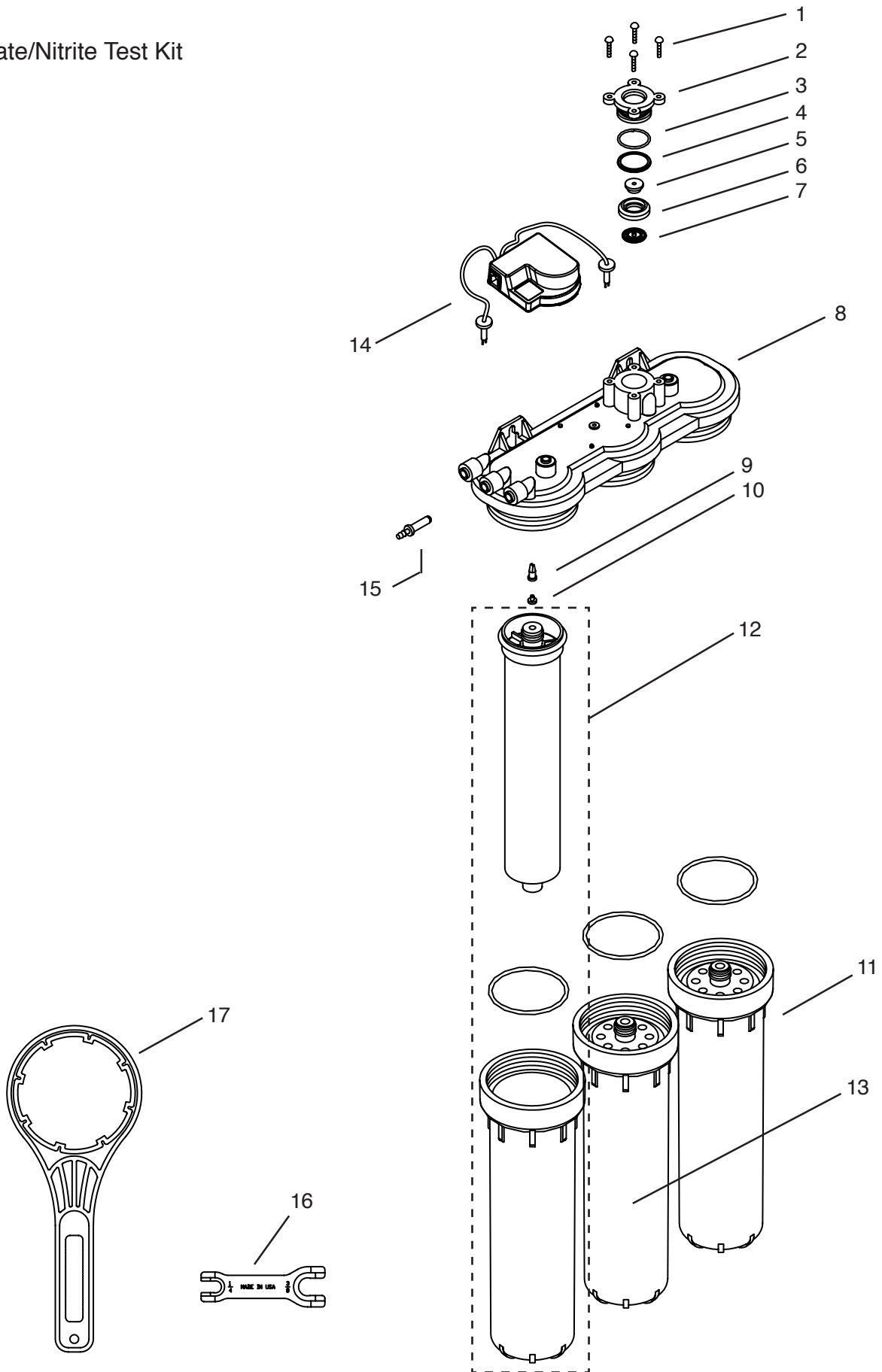

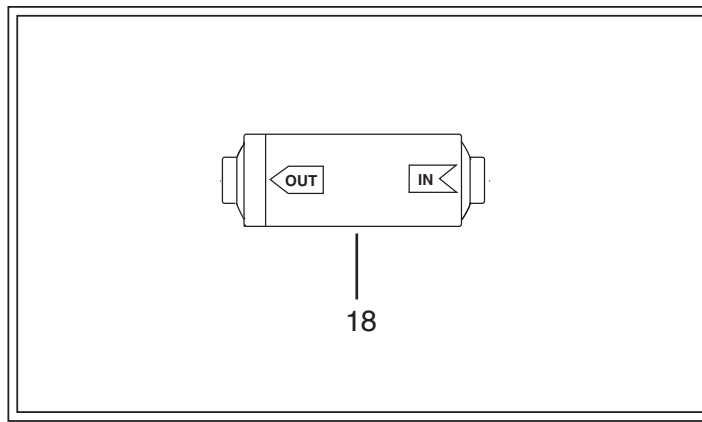

DRAWING NO.	PART NO.	DESCRIPTION
1.....	S2009.....	Self Tapping Screw
2.....	S2005.....	ASO Cap
3.....	S2013.....	ASO Cap O-Ring
4.....	S2011.....	ASO Diaphragm – Large
5.....	S2007.....	ASO Piston
6.....	S2006.....	ASO Piston Ring
7.....	S2010.....	ASO Diaphragm – Small
8.....	NSTFC0305MNG.....	Manifold Plate Assembly with Monitor (Includes diagram numbers 1 through 10, 15 and 16.)
9.....	S1276.....	Check Valve
10.....	S1277.....	Check Valve Retainer
11.....	S7113X.....	Sediment Module
12.....	S1340RS.....	T.F.C. RO Membrane 50 gpd/189 lpd
13.....	S7225X.....	Activated Carbon Module
14.....	R7078.....	Water Quality Monitor Board w/Probes and Cover
15.....	S2116-5.....	Drain Restrictor 50 GPD/189 lpd Green
16.....	S1405.....	1/4"-3/8" Fitting Wrench
17.....	S3072.....	Wrench for Housing
18.....	S7206W-JG.....	In-Line Activated Carbon Post Filter
19.....	S1447.....	Nitrate/Nitrite Test Kit
(shown on pg. 6)....	R2118.....	Water Quality Monitor 25 Ft. Extension Cable

OTHER COMPONENTS AS SHOWN IN FIGURE 1, PAGE 5.

DRAWING NO.	PART NO.	DESCRIPTION
1.....	R7101-CR.....	Dispensing Faucet w/Monitor Base
3.....	S1117-01.....	3/8" Drain Clamp Assembly
4.....	S2119-01NN.....	Cover
7.....	JG-PI301208S.....	3/8" x 3/8" x 1/4" Union Tee
8.....	S1118-01.....	Feed Water Saddle Valve
9.....	C2000FP.....	Holding Tank
10.....	S1037.....	Holding Tank Shut-Off Valve



GE Pro Elite™ DRINKING WATER SYSTEM
FIVE/ONE YEAR LIMITED WARRANTY

What Does This Warranty Cover?

This warranty covers any defects in materials and workmanship of the GE Pro Elite™ Drinking Water System when installed and operated within recommended parameters, with the exceptions stated below.

How Long Does The Coverage Last?

The LeverEdge will warrant its GE Pro Elite™ Drinking Water System (except for the reverse osmosis membrane), for a period of five years from the date of purchase. The reverse osmosis membrane is warranted for one year from date of purchase. All implied warranties including merchantability and fitness for a particular purpose are limited to five years from the date of purchase for the GE Pro Elite™ Drinking Water System, except for the reverse osmosis membrane which is limited to one year from date of purchase. Some states do not allow limitations on how long an implied warranty lasts, so the above limitations may not apply to you.

What Will The LeverEdge Do?

The LeverEdge will repair or replace at its discretion any defective component. You must pay any labor charges. You must also pay for shipping or travel charges to return the defective part(s).

What Does This Warranty Not Cover?

This warranty does not cover the disposable sediment and carbon modules whose service life depends on feed water conditions. In addition, the membrane is only warranted if the required feed water conditions are met.

The above warranty will also not apply to any part of the GE Pro Elite™ Drinking Water System that is damaged because of neglect, misuse, alterations, accident, misapplication, physical damage, or damage caused by fire, acts of God, freezing or hot waters or similar causes. Consequential and incidental damages are not recoverable under this warranty. Some states do not allow the exclusion or limitation of incidental or consequential damages, so the above limitation or exclusion may not apply to you.

We recommend that you use only authorized replacement parts since improper parts or incorrectly performed maintenance or repair voids this warranty.

How Do You Get Service?

In order to be eligible for service under this warranty you must (a) contact your local dealer who supplied the unit or (b) contact the factory for the dealer nearest you.

How Does State Law Apply?

This warranty gives you specific legal rights and you may also have other rights which vary from state to state.

Manufactured by
The LeverEdge
4305 West Alva Street
Tampa, FL 33614
Phone: (813) 875-5300
www.TheLeverEdge.com